

Agilent 83433A 10 Gb/s Lightwave Transmitter

Agilent 83434A 10 Gb/s Lightwave Receiver

Product Overview

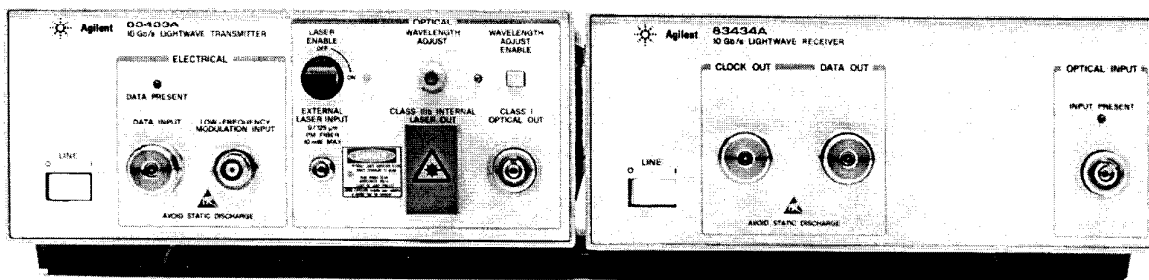

83433A

- Excellent 10 Gb/s and 2.5 Gb/s optical waveforms
- Modulate at data rates from 2.4 to 10.7 Gb/s
- Generates STM-64/OC-192 and STM-16/OC-48 compliant eye patterns with appropriate data input
- 1550 nm ITU-T grid wavelength internal DFB laser with Mach-Zehnder modulator
- Compatible with external polarization controlled TLS at wavelengths from 1530 to 1565 nm

83434A

- Choice of lock recovery at 9953.28 MHz or 10.664228 GHz (FEC) with option 106
- PIN diode-based receiver, wavelength range 1300 to 1600 nm
- Linear, non-retimed data output
- -16 dBm sensitivity (BER of 1×10^{-10} for 2³¹-1 PRBS)



Agilent Technologies

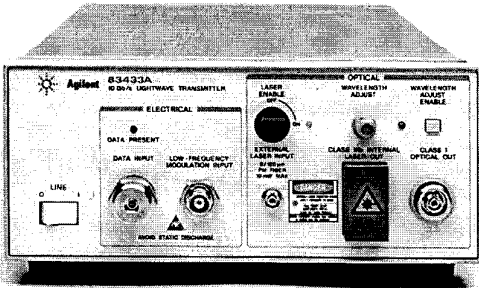

Agilent 83433A transmitter

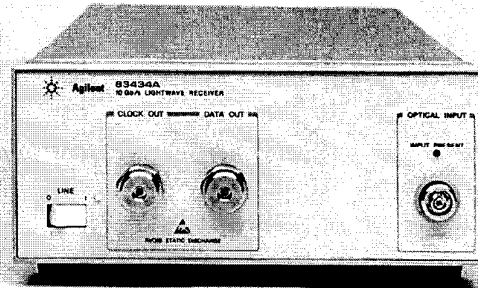

Agilent 83434A receiver

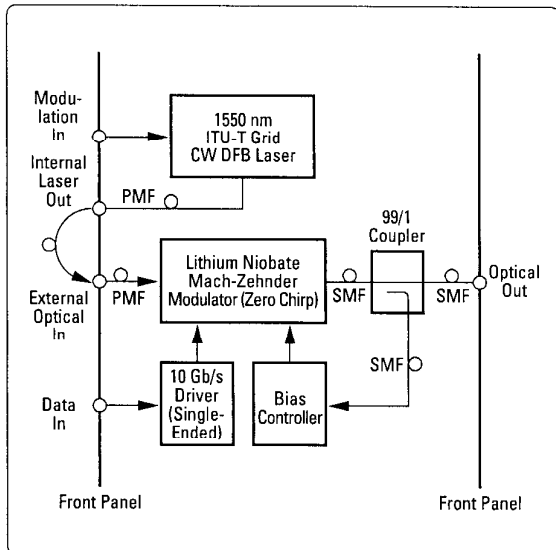

83433A block diagram

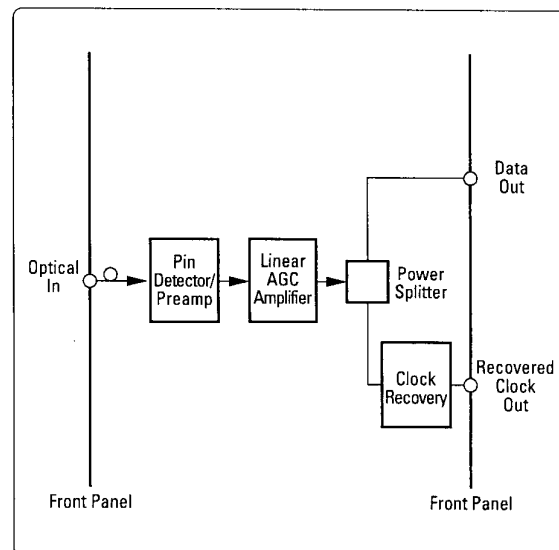

83434A block diagram

10 Gb/s Optical Interfaces for Bit Error Ratio Testing

The Agilent 83433A transmitter and the Agilent 83434A receiver provide the optical interfaces necessary to allow bit error ratio testing of 10 Gb/s optical transmitters and receivers used in 10 Gb/s SONET/SDH and IP optical networks as well as systems employing forward error correction (FEC). The 83433A and 83434A may be combined to create a complete optical link for system or fiber testing.

The 83434A receiver's non-retimed output is designed for use with the Agilent 71612C 12.5 Gb/s Error Performance Analyzer. The 71612C can optimize the receiver output decision

threshold and timing to optimize BER. Because of this, Q-factor and eye contour analysis for optical signal degradation testing can be accomplished using the 83434A, 71612C and the E4543A Q-factor and eye-contour analysis software.

The 83434A receiver recovers clock and data from digitally modulated SONET/SDH OC-192/STM-64 optical signals. Option 106 substitutes clock recovery for FEC signals at 10.664 GHz. The amplified PIN-diode produces a linear output with AGC stabilization. The receiver is designed to provide -16 dBm sensitivity for a $2^{31}-1$ PRBS with a BER performance of at least 1×10^{-10} .

10 Gb/s Clock Recovery for Oscilloscope Triggering

The 83434A receiver can also be used for optical eye diagram analysis with a sampling oscilloscope, such as the 86100A Infinium DCA, when no separate clock signal is available or when an optical channel is not available. The 83434A's clock output can be used to trigger an oscilloscope at 9.953 Gb/s (or 10.664 Gb/s with option 106) ensuring that the eye diagram is an accurate representation of all possible bit combinations on the incoming data stream. The non-retimed linear data output allows for diagnostic analysis of the incoming waveform.

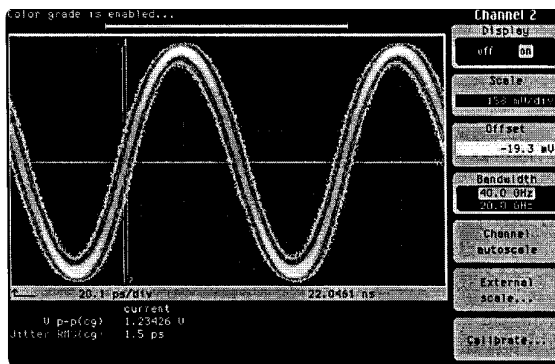

Agilent 83434A recovered clock output at 9953.28 MHz*

Excellent Waveform Generation for General Purpose Testing

The 83433A transmitter with the 71612C Error Performance Analyzer can produce high fidelity, low jitter waveforms for 2.488 Gb/s STM-16/OC-48, 9.953 Gb/s STM-64/OC-192, and other transmission rates from 2.4 Gb/s through 10.7 Gb/s. The Mach-Zehnder modulator is adjusted for a fixed zero chirp. Its output waveform produces a nominal extinction ratio of 12 dB. The internal DFB laser may be modulated at frequencies from 15 kHz to 10 MHz to increase line-width for SBS suppression. The laser's center wavelength can be manually adjusted ± 1 nm around the specified ITU-T grid center wavelength.

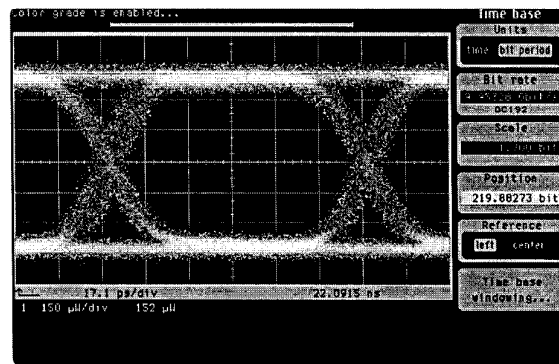

Agilent 83433A unfiltered optical waveform at 9953.28 Mb/s*

10 Gb/s DWDM Testing

The 83433A transmitter was designed with DWDM testing in mind. The internal laser standard wavelength is one of the ITU-T grid wavelengths between 1548.41 nm and 1556.65 nm. The 83433A allows low frequency modulation of the internal laser to facilitate channel identification applications. An external tunable laser source with polarization maintaining fiber, such as the Agilent 8164B with 81680A option 071, can be used with the front panel input to the lithium niobate Mach-Zehnder modulator to test channel crosstalk, or the internal laser and modulator can be connected externally with the supplied semi-rigid PMF fiber.

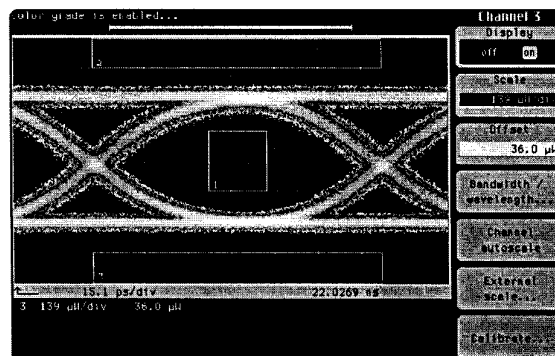

Agilent 83433A filtered optical waveform at 9953.28 Mb/s with time-scaled OC-48 mask*

* Driven with Agilent 71612B Error Performance Analyzer

Performance Specifications and Characteristics

Specifications describe the instrument's warranted performance over the operating temperature range except where noted. Characteristics (in Italics) provide information about non-warranted instrument performance in the form of nominal values.

Agilent 83433A Lightwave Transmitter

Digital Data Input

	Min	Nominal	Max	Units
Data rate compatibility ²³	2.4		10.7	Gb/s
Amplitude ¹	0.5		1.5	V pk-pk
Return loss				
0.1 to 5000 MHz	12			dB
5000 to 10,700 MHz	9			dB
Impedance		50		Ohms
Mark density	45		55	%
Max run of consecutive "ones" or "zeros"		100		bits
Polarity		Non-inverting		

Maximum Safe Input Level

	Max Level	Units
Digital data input	2.0	V pk-pk
	+2.0, -2.0	V dc
Low-frequency modulation input	2.0	V pk-pk
External optical modulator input ²	+14	dBm

Low-Frequency Modulation Input

	Min	Nominal	Max	Units
Frequency range				
3 dB points	0.015		10	MHz
Amplitude for 5% mod index ¹	0.5	1	1.5	V pk-pk
Impedance		50		Ohms
Polarity		Inverting		

Internal Laser Output

	Min	Nominal	Max	Units
CW Power ³	+8.5	+10	+11.5	dBm
Wavelength ^{4,24}	1548.41		1556.65	nm
Wavelength adjustment range	-1		+1	nm
Spectral width at -20 dBc FWHM			10	MHz
Side-mode suppression ratio	30			dB

Optical Modulator Input

	Min	Nominal	Max	Units
Wavelength	1530		1565	nm
Optical power input ²	+2		+12	dBm
Input return loss	27			dB

Modulated Optical Output

	Min	Nominal	Max	Units
Modulator insertion loss	3	5	7	dB
Optical power output ⁵	0		+5.5	dBm
Output return loss	27			dB
Extinction ratio ⁶	12			dB
Jitter generation ⁷				
OC-192 data rate ⁶			0.15	UI pk-pk
Eye mask				
OC-192 data rate	Meets GR-253-CORE (scaled to data rate)			
OC-48 data rate	Meets GR-253-CORE			

General

Digital data input connector

APC-3.5 male

Low-frequency modulation input connector

BNC female

Internal laser output connector

FC/PC⁸

Optical modulator input connector

FC/PC⁸

Modulated optical output connector

Diamond HMS-10/HP⁹

Optical jumper cable

Includes semi-rigid, polarization maintaining fiber to connect internal laser output and optical modulator input

Laser safety

21 CFR 1040 Class IIb, IEC 60825-1 Class 3B

General safety

Meets or exceeds CAN/CSA-C22.2 NO.1010 and EN 61010/TEC 61010-1 and all amendments

EMI

Radiated and conducted emissions are in compliance with the requirements of CISPR Publication 11, Class A and immunity in compliance with IEC 61326-1

Power

100, 120, 220, 240 VAC ($\pm 10\%$), 47 to 63 Hz

Operating temperature

0 to +45°C

Storage temperature

-40 to +70°C

Weight

3.5 kg (7.8 lbs)

Dimensions

102 mm (4 in) height, 216 mm (8.5 in) width, 444 mm (17.5 in) depth (Agilent System II, half-width case)

Agilent 83434A Lightwave Receiver

Optical Input

	Min	Nominal	Max	Units
Wavelength	1300		1600	nm
Optical input power ^{10,11,12,13}	-16		0	dBm
Return loss	28			dB
"Loss of optical input" Alarm Threshold	-25		-20	dBm

Maximum Safe Input Level

	Max Level	Units
Optical input power ¹⁴	+7	dBm

Data Output

	Min	Nominal	Max	Units
Amplitude ^{15,16}	0.5		1.5	V pk-pk
Lower 3 dB frequency ¹			0.10	MHz
Upper 3 dB frequency ^{1,18}	6.5			GHz
Return loss ¹⁷	9.5			dB
Impedance		50		ohms

Recovered Clock Output

	Min	Nominal	Max	Units
Amplitude ¹	0.5		1.5	V pk-pk
Frequency ^{19,23}	9953.26	9953.28	9953.30	MHz
Option 106	10664.028	10664.228	10664.428	MHz
Duty cycle		50/50	45/55	%
Clock to data alignment ²⁰			±25.12	ps
Jitter transfer bandwidth ¹⁹	4	5	6	MHz
Jitter generation ^{16,21}			2	ps rms
Return loss ²²	12			dB
Impedance		50		ohms

General

Optical input connector

Diamond HMS-10/HP⁹

Data output connector

APC-3.5 male

Recovered clock output connector

APC-3.5 male

General safety

Meets or exceeds CAN/CSA-C22.2 NO.1010 and EN 61010/IEC 61010-1 and all amendments

EMI

Radiated and conducted emissions are in compliance with the requirements of CISPR Publication 11, Class A and immunity in compliance with IEC 61326-1

Power

100, 120, 220, 240 VAC (±10%), 47 to 63 Hz

Operating temperature

0 to +45°C

Storage temperature

-40 to +70°C

Weight

3.4 kg (7.6 lbs)

Dimensions

102 mm (4 in) height, 216 mm (8.5 in) width, 444 mm (17.5 in) depth (Agilent System II, half-width case)

¹ AC coupled

² Input power greater than +10 dBm may cause modulated optical output power to exceed Class I level.

³ Class IIIb laser output.

⁴ Wavelength adjustment disabled

⁵ Average power with internal laser modulated with 2³¹-1 PRBS

⁶ Measured with 1 V pk-pk data input signal and 2³¹-1 PRBS on an 83480A, 83485B with OC-192 filter.

⁷ Applies over the temperature range 0 to 30°C

⁸ Panda polarization-maintaining fiber with slow axis aligned to key

⁹ Standard instrument has FC/PC adapters. Other adapters available as options.

¹⁰ Better than 1 x 10⁻¹⁰ BER when tested with Agilent 71612B using either of two patterns:

a) 2³¹-1 PRBS, or b) 100 consecutive "ones" or "zeros" on a 2³¹-1 PRBS

¹¹ Source extinction ratio ≥8.2 dB measured within ±10% of eye center

¹² Applies over the temperature range 25°C ±10°C.

¹³ Tested with FC/PC adapter.

¹⁴ 1310 or 1550 nm

¹⁵ Non-inverting, non-retimed linear output with AGC stabilization

¹⁶ For PRBS up to and including 2³¹-1

¹⁷ 0.01 to 10,700 MHz

¹⁸ Measured with swept network analyzer at -8 dBm optical input with fixed AGC control in Tx and Rx.

¹⁹ Type A resonator based clock recovery

²⁰ Falling clock edge to data transition measured with 2³¹-1 PRBS.

²¹ Integrated phase noise measurement method.

²² 9,940 to 9,960 MHz standard, 10624 to 10684 MHz option 106

²³ For NRZ data format

²⁴ Actual wavelength will be one of the ITU-T grid wavelengths between 1548.41 nm and 1556.65 nm ±0.1 nm. Wavelength adjustment range is ±1 nm.

Ordering Information

- Agilent 83433A** 10 Gb/s Lightwave Transmitter
Includes FC/PC connector interface on modulated optical output. Includes semi-rigid Panda polarization-maintaining fiber for connection between internal laser output and external optical modulator input. Standard instrument has a center wavelength at one of the ITU-T grid wavelengths between 1548.41 nm and 1556.65 nm.

Options to replace standard laser with other ITU-grid wavelength laser available upon request.

- Agilent 83434A** 10 Gb/s Lightwave Receiver
Includes FC/PC connector interface on optical input. Standard instrument has clock recovery at 9953.28 MHz.

- Option 106** Replaces clock recovery at SDH/SONET STM-64/OC-192 with FEC 10.664228 GHz

Option to replace clock recovery at 9953.28 MHz with 10.3125 GHz available upon request.

Connector options to replace the standard FC/PC connector interface of the 83433A modulated optical output and the 83434A optical input:

- Option 011** Diamond (HMS-10) connector
- Option 013** DIN connector
- Option 014** ST connector
- Option 017** SC connector

For additional connector interfaces order the Agilent 81000XI series.

Related Products

- Agilent 83430A** 2.5 Gb/s Lightwave Digital Source
- Agilent 83446A** 2.5 Gb/s Lightwave Clock/Data Receiver
- Agilent 86130A** 3.6 Gb/s Error Performance Analyzer
- Agilent 71612C** 12.5 Gb/s Error Performance Analyzer
- Agilent E4543A** Q-factor and Eye-contour Analysis Software
- Agilent 86100A** Infinium DCA
- Agilent 8164B with 81680A option 071** Tunable Laser Source

By internet, phone, or fax, get assistance with all your test & measurement needs.

Online assistance:
www.agilent.com/comms/lightwave

Phone or Fax

United States:

(tel) 1 800 452 4844

Canada:

(tel) 1 877 894 4414

(fax) (905) 282 6495

China:

(tel) 800-810-0189

(fax) 1-0800-650-0121

Europe:

(tel) (31 20) 547 2323

(fax) (31 20) 547 2390

Japan:

(tel) (81) 426 56 7832

(fax) (81) 426 56 7840

Korea:

(tel) (82-2) 2004-5004

(fax) (82-2) 2004-5115

Latin America:

(tel) (305) 269 7500

(fax) (305) 269 7599

Taiwan:

(tel) 080-004-7866

(fax) (886-2) 2545-6723

Other Asia Pacific Countries:

(tel) (65) 375-8100

(fax) (65) 836-0252

Email: tm_asia@agilent.com

Product specifications and descriptions in this document subject to change without notice.

© 2000 Agilent Technologies, Inc.
Printed in USA December 1, 2001
5968-9251E



Agilent Technologies